



STANDBY GENERATORS

8 kVA - 10 kVA - 13 kVA

Air-Cooled Gas Engine Generator Sets

INCLUDES:

- Tri-ligual Two Line LCD Digital Nexus™ Controller (English/Spanish/French)
- Electronic Governor
- External Main Circuit Breaker & System Status LED
- Flexible Fuel Line Connector
- Composite Mounting Pad
- Natural Gas or LP Gas Operation

Standby Power Rating

Model 005914-0 (Steel - Bisque) - 8 kVA 50Hz

Model 005915-0 (Steel - Bisque) - 10 kVA 50Hz

Model 005916-0 (Steel - Bisque) - 13 kVA 50Hz



FEATURES

- **INNOVATIVE DESIGN & PROTOTYPE TESTING** are key components of Generac's success in "IMPROVING POWER BY DESIGN." But it doesn't stop there. Total commitment to component testing, reliability testing, environmental testing, destruction and life testing, allows you to choose Generac with the confidence that these systems will provide superior performance.
- **TEST CRITERIA:**
 - ✓ **PROTOTYPE TESTED**
 - ✓ **MOTOR STARTING ABILITY**
 - ✓ **SYSTEM TORSIONAL TESTED**
- **SOLID-STATE, FREQUENCY COMPENSATED VOLTAGE REGULATION:** This state-of-the-art power maximizing regulation system is standard on all Generac models. It provides optimized FAST RESPONSE to changing load conditions and MAXIMUM MOTOR STARTING CAPABILITY by electronically torque-matching the surge loads to the engine.
- **SINGLE SOURCE SERVICE RESPONSE** from Generac's dealer network provides parts and service know-how for the entire unit, from the engine to the smallest electronic component.

GENERAC®

FEATURES

Generac Standby Generator - 8 kVA - 10 kVA - 13 kVA

ENGINE	<ul style="list-style-type: none"> •Generac (OHVI) Design 	Maximizes engine “breathing” for increased fuel efficiency. Plateau honed cylinder walls and plasma moly rings help engine run cooler, reducing oil consumption. Because heat is the primary cause of engine wear, the OHVI has a significantly longer life than competitive engines.
	<ul style="list-style-type: none"> •“Spiny-lok” cast iron cylinder walls 	Rigid construction and added durability provide long engine life.
	<ul style="list-style-type: none"> •Electronic ignition 	This assures smooth, quick starting every time.
	<ul style="list-style-type: none"> •Full pressure lubrication system 	Superior lubrication to all vital bearings means better performance, less maintenance and significantly longer engine life. Now featuring a 2 year/200 hour oil change interval.
	<ul style="list-style-type: none"> •Low oil pressure shutdown system •High temperature shutdown 	Superior shutdown protection prevents catastrophic engine damage due to low oil. Prevents damage due to overheating.
GENERATOR	<ul style="list-style-type: none"> •Revolving field 	Allows for smaller, light weight unit that operates 25% more efficiently than a revolving armature generator.
	<ul style="list-style-type: none"> •Skewed stator 	Produces a smooth output waveform for compatibility with electronic equipment.
	<ul style="list-style-type: none"> •Displaced phase excitation 	Maximizes motor starting capability.
	<ul style="list-style-type: none"> •Automatic voltage regulation 	Regulates the output voltage to $\pm 2\%$ prevents damaging voltage spikes.
CONTROLS	<ul style="list-style-type: none"> •Manual/Auto/Off switch 	Selects the operating mode.
	<ul style="list-style-type: none"> •Utility voltage sensing 	Constantly monitors utility voltage, setpoints 65% dropout, 75% pick-up, of standard voltage.
	<ul style="list-style-type: none"> •Utility interrupt delay 	Prevents nuisance start-ups of the engine, setpoint approximately 10 seconds.
	<ul style="list-style-type: none"> •Engine warm-up 	Ensures engine is ready to assume the load, setpoint approximately 10 seconds.
	<ul style="list-style-type: none"> •Engine cool-down 	Allows engine to cool prior to shutdown, setpoint approximately 1 minute.
	<ul style="list-style-type: none"> •Seven day exerciser 	Operates engine to prevent oil seal drying and damage between power outages.
	<ul style="list-style-type: none"> •Trickle Battery charger 	Maintains battery charge level to insure starting.
UNIT	<ul style="list-style-type: none"> •Main Line Circuit Breaker 	Protects generator from overload.
	<ul style="list-style-type: none"> •Electronic governor 	Maintains constant 50 Hz frequency.
	<ul style="list-style-type: none"> •Weather protective enclosure 	Ensures protection against mother nature. Hinged key locking roof panel for security. Lift-out front for easy access to all routine maintenance items. Electrostatically applied textured epoxy paint for added durability.
INSTALLATION SYSTEM	<ul style="list-style-type: none"> •Enclosed critical grade muffler 	Quiet, critical grade muffler is mounted inside the unit to prevent injuries.
	<ul style="list-style-type: none"> •Small, compact, attractive 	Makes for an easy, eye appealing installation.
	<ul style="list-style-type: none"> •1' Flexible Fuel Line Connector •Composite Mounting Pad 	Easy Installation

SPECIFICATIONS

GENERAC®

GENERATOR	Model 005914-0 (8 kVA)	Model 005915-0 (10 kVA)	Model 005916-0 (13 kVA)
Rated Maximum Continuous Power Capacity (LP)	8,000 Watts*	10,000 Watts*	13,000 Watts*
Rated Maximum Continuous Power Capacity (NG)	8,000 Watts**	10,000 Watts**	13,000 Watts**
Rated Voltage	110/220	110/220	110/220
Rated Maximum Continuous Load Current 220 Volts, Single Phase	33.3 LP/33.3 NG	45.5 LP/45.5 NG	59 LP/59 NG
Main Line Circuit Breaker	35 Amp	50 Amp	65 Amp
Phase	1	1	1
Number of Rotor Poles	2	2	2
Rated AC Frequency	50Hz	50Hz	50Hz
Power Factor	1	1	1
Battery Requirement (not included)	Group 26 12 Volts and 525 Cold-cranking Amperes Minimum	Group 26 12 Volts and 525 Cold-cranking Amperes Minimum	Group 26 12 Volts and 525 Cold-cranking Amperes Minimum
Unit Weight (Pounds/Kilograms)	387/175.4	425.5/193	445/201.8
Dimensions L x W x H (Inches/Millimeters)	48 x 25 x 29/1218 x 638 x 732	48 x 25 x 29/1218 x 638 x 732	48 x 25 x 29/1218 x 638 x 732
ENGINE	Model 005914-0 (8 kVA)	Model 005915-0 (10 kVA)	Model 005916-0 (13 kVA)
Type of Engine	GENERAC OHVI V-TWIN	GENERAC OHVI V-TWIN	GENERAC OHVI V-TWIN
Number of Cylinders	2	2	2
Displacement	530cc	992cc	992cc
Cylinder Block	Aluminum w/Cast Iron Sleeve	Aluminum w/Cast Iron Sleeve	Aluminum w/Cast Iron Sleeve
Valve Arrangement	Overhead Valve	Overhead Valve	Overhead Valve
Ignition System	Solid-state Magneto	Solid-state Magneto	Solid-state Magneto
Governor System	Electronic	Electronic	Electronic
Compression Ratio	9.5:1	9.5:1	9.5:1
Starter	12 Vdc	12 Vdc	12 Vdc
Oil Capacity Including Filter (Quarts/Liters)	1.7/1.6	1.9/1.8	1.9/1.8
Operating RPM	3,000	3,000	3,000
Fuel Consumption			
Natural Gas	cu.ft./hr. (cu.meters/hr.)		
	1/2 Load		
	Full Load		
Liquid Propane	cu.ft./hr (gal/hr)/cu.meters/hr. (liters/hr.)		
	1/2 Load		
	Full Load		
*Required fuel pressure to generator fuel inlet at all load ranges - 5 to 7 inches of water column for natural gas, 11 to 14 inches of water column for LP gas			
**Outputs are based upon natural gas value @ 1000 Btu per cubic feet and 2520 Btu per cubic feet with LP @ 28.32 Btu per cubic meter and 71.36 Btu per cubic meter with LP			
CONTROLS			
2-Line Plain Text LCD Display	Simple user interface for ease of operation		
Mode Switch			
-Auto	Automatic Start on Utility failure. 7 day exerciser		
-Off	Stops unit. Power is removed. Control and charger still operate.		
-Manual/Test (start)	Start with starter control, unit stays on. If utility fails, transfer to load takes place.		
Engine Start Sequence	Cyclic cranking: 16 sec. on, 7 rest (90 sec. maximum duration)		
Engine Warm-up	10 seconds		
Engine Cool-Down	1 minute		
Starter Lock-out	Starter cannot re-engage until 5 sec. after engine has stopped.		
2.5 Amp Trickle Battery Charger	Standard		
Automatic Voltage Regulator w/Overvoltage Protection	Standard		
Automatic Low Oil Pressure Shutdown	Standard		
Overspeed Shutdown	Standard, 60Hz		
High Temperature Shutdown	Standard		
Overcrank Protection	Standard		
Safety Fuse	Standard		

Rating definitions - All ratings in accordance with BS5514, ISO3046 and DIN6271. * Maximum wattage and current are subject to and limited by such factors as fuel Btu content, ambient temperature, altitude, engine power and condition, etc.

Maximum power decreases about 3.5 percent for each 1,000 feet (304.8 meters) above sea level; and also will decrease about 1 percent for each 12° C (10° F) above 15.5° C (60°F).

Generac Standby Generator - 8 kVA - 10 kVA - 13 kVA

Design and specifications subject to change without notice. Dimensions shown are approximate. Contact your Carrier dealer for certified drawings. DO NOT USE THESE DIMENSIONS FOR INSTALLATION PURPOSES.

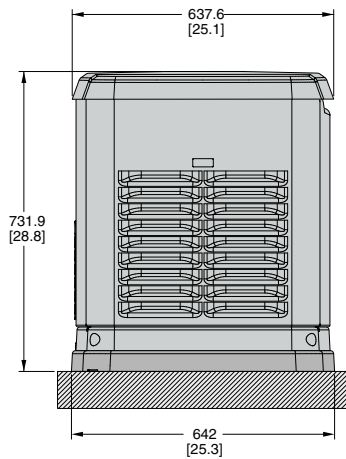

LEFT SIDE VIEW

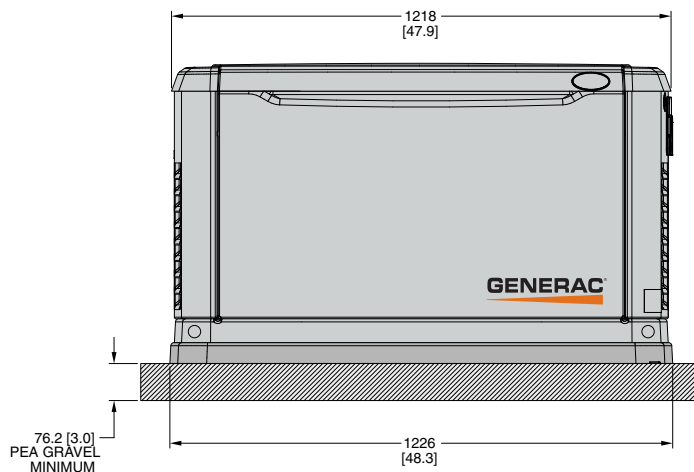

FRONT VIEW



Generac Power Systems, Inc. • S45 W29290 HWY. 59, Waukesha, WI 53189 • generac.com

©2009 Generac Power Systems, Inc. All rights reserved. All specifications are subject to change without notice. Bulletin 0190490SBY-A / Printed in U.S.A. 11/18/10